

ANDERSEN 5TH WHEEL HITCH CONFIGURATION CHART

• This guide is accurate for most newer configurations. However, we do NOT guarantee that the indicated hitches will work in all setups. •

Contact your Andersen Rep or Customer Service if you have questions about a particular setup.

	Solid Pin Box		Moveable Pin Box					Bed Size				Bed Configuration		
	Under 30"	Over 30"	MORryde	Air Bag style	Rota-Flex	Airbourne	Pivoting style	5.5'	6.5'	8'	Flatbed**	Industry Standard Rails	Gooseneck Ball	Puck System
U5 - RAIL 3200 Ultimate 5th Wheel Connection (Rail Mount)														
	YES	YES	YES w/ MORryde #RPB710-009 ²	YES	YES w/ Lock-Out kit (part 3247)	YES	YES If Locked Straight	YES No on 2020 GM Trucks ¹	YES	YES	NO	YES	NO	With Rail Adapter *
U5 - RAISED 3217 Ultimate 5th Wheel Connection (Gooseneck Mount - raised version for tall side rails)														
	YES	YES	YES w/ MORryde #RPB710-009 ²	YES	YES w/ Lock-Out kit (part 3247)	YES	YES If Locked Straight	YES Yes on 2020 GM Trucks ³	YES	YES	NO	NO	On 2-5/16" Ball (see tube chart)	On Bed Shaft (part 3219) or 2-5/16" Ball (see tube chart)
U5 - GOOSENECK 3220 Ultimate 5th Wheel Connection (Gooseneck Mount)														
	YES	YES	YES w/ MORryde #RPB710-009 ²	YES	YES w/ Lock-Out kit (part 3247)	YES	YES If Locked Straight	YES **No on 2020 GM Trucks ¹	YES	YES	NO	NO	On 2-5/16" Ball (see tube chart)	On Bed Shaft (part 3219) or 2-5/16" Ball (see tube chart)
U5 - GOOSENECK 3220-TBX Ultimate 5th Wheel Connection (Gooseneck Mount - toolbox version)														
Toolbox Version (≈ 3.5" base offset for use in bed with large fuel tank or toolbox)	YES	YES	YES w/ MORryde #RPB710-009 ²	YES	YES w/ Lock-Out kit (part 3247)	YES	YES If Locked Straight	YES **No on 2020 GM Trucks ¹	YES	YES	NO	NO	On 2-5/16" Ball (see tube chart)	On Bed Shaft (part 3219) or 2-5/16" Ball (see tube chart)
U5 - FLATBED 3221 Ultimate 5th Wheel Connection (Gooseneck Mount for flatbed trucks)														
	YES	YES	YES w/ MORryde #RPB710-009 ²	YES	YES w/ Lock-Out kit (part 3247)	YES	YES If Locked Straight	NO	NO	NO	YES **	NO	On 2-5/16" Ball (see tube chart)	NO
U5 - FLATBED 3221-TBX Ultimate 5th Wheel Connection (Gooseneck Mount for flatbed trucks - toolbox version)														
Toolbox Version (≈ 3.5" base offset for use in bed with large fuel tank or toolbox)	YES	YES	YES w/ MORryde #RPB710-009 ²	YES	YES w/ Lock-Out kit (part 3247)	YES	YES If Locked Straight	NO	NO	NO	YES **	NO	On 2-5/16" Ball (see tube chart)	NO
RANCH HITCH 3100 Ranch Hitch Adapter - Straight														
	YES	YES***	With Adapter *	NO	NO	NO	NO	NO	YES	YES	NO	With Adapter *	On 2-5/16" Ball	On 2-5/16" Ball
RANCH HITCH 3139 Ranch Hitch Adapter - 8" Offset														
	NO Fits Pin Boxes of 22" or less***	NO	With Adapter *	NO	NO	NO	NO	YES	YES	YES	NO	With Adapter *	On 2-5/16" Ball	On 2-5/16" Ball

* Adapters are available from the pinbox or rail manufacturer.

** Works with recessed ball.

*** Gusset recommended.

IMPORTANT: Extra bed support is recommended for 2015-2019 models of Chevy & GMC trucks with no OEM, when a gooseneck mount Ultimate Connection base is used. (Contact us for details 208.523.6460)

- 2020 GM TRUCKS: the Ultimate Connection (3220 & 3220-TBX) may not provide enough clearance in 2020 Chevy & GMC trucks. **ALWAYS MEASURE FOR TURNING, TAIL GATE, AND SIDE RAIL CLEARANCE.**
- MORryde Pin Box: This is compatible with all versions of the Ultimate ONLY when installed with MORryde Part #: RPB77-006. This part can be ordered from MORryde or from your local MORryde dealer.
- The raised Ultimate Connection (3217) is recommended only for newer models of trucks (2020 and newer). Use on 2019 or older trucks may add unnecessary leverage on the truck bed and excessive height.

ULTIMATE CONNECTION COUPLER TUBE CHARTS

ULTIMATE
5TH WHEEL
 CONNECTION

3217, 3220, & 3220-TBX

IMPORTANT:
 Always specify if top of ball is **ABOVE** or **BELOW** truck bed

 If your ball has a flat top, subtract 1/8" from these ball height measurements. (e.g. 3-3/4" becomes 3-5/8")

STANDARD ON 3220

STANDARD ON 3217

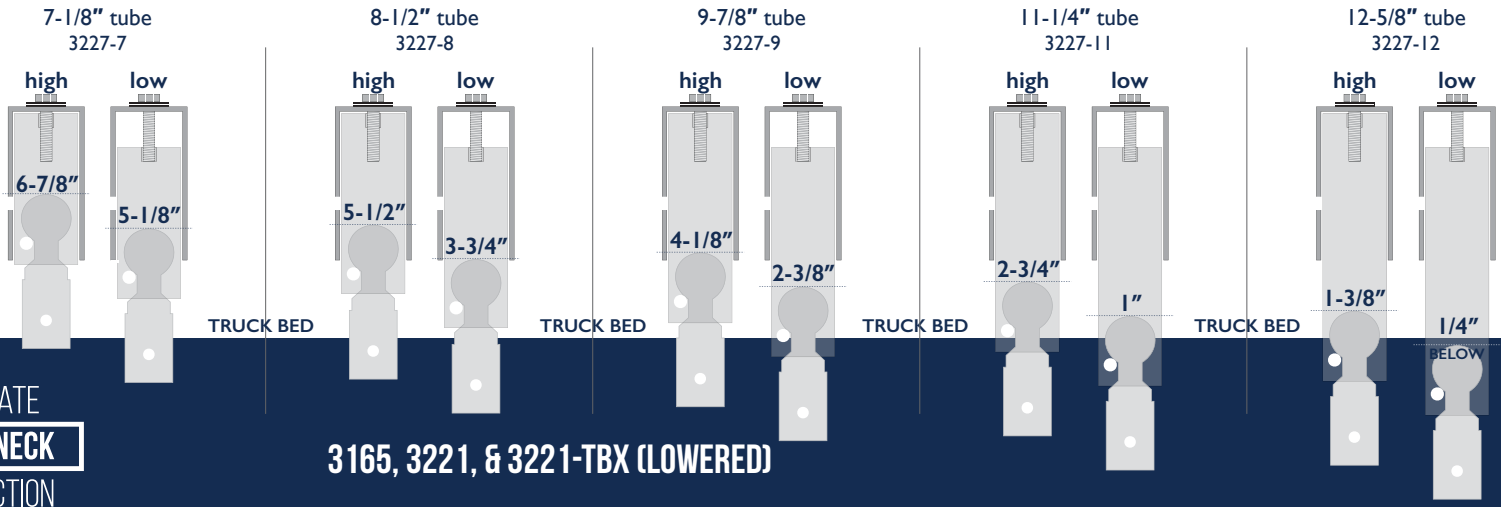

ULTIMATE
5TH WHEEL
 CONNECTION

ULTIMATE
GOOSENECK
 CONNECTION

3165, 3221, & 3221-TBX (LOWERED)

STANDARD ON 3165

STANDARD ON 3221

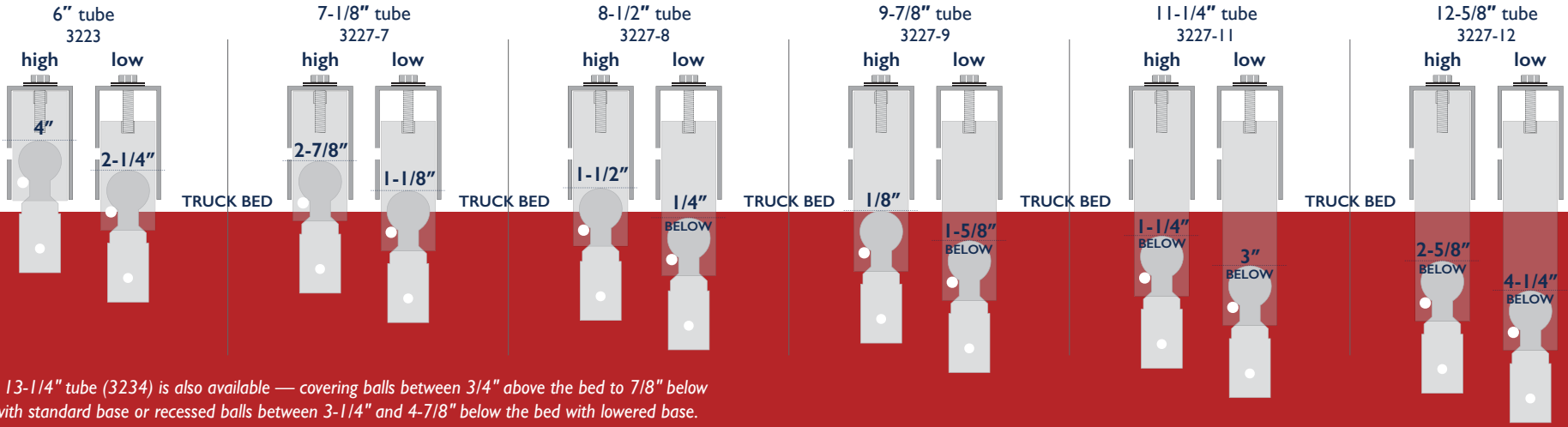

• Extended 13-1/4" tube (3234) is also available — covering balls between 3/4" above the bed to 7/8" below the bed with standard base or recessed balls between 3-1/4" and 4-7/8" below the bed with lowered base.